

THIS DRAWING IS UNPUBLISHED. RELEASED FOR PUBLICATION, 19 .
 © COPYRIGHT 19 BY AMP INCORPORATED. ALL INTERNATIONAL RIGHTS RESERVED.

LOC	DIST	P	F	REVISIONS				
				ZONE	LTR	DESCRIPTION	DATE	APPD
AF	50				F	ADDED -1 PER 0L10-0236-96	12/13/96	JR/PD

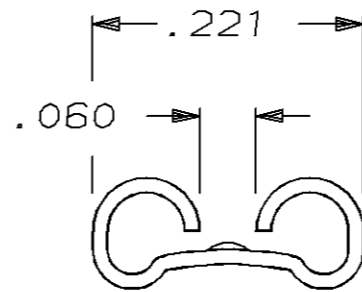
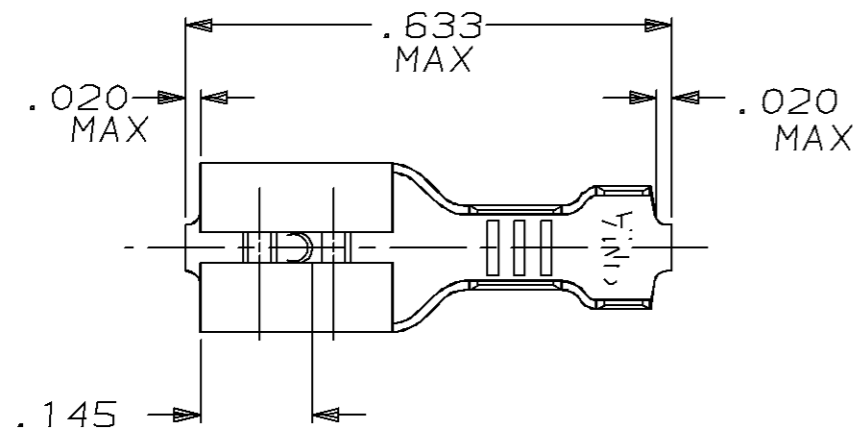

VIEW A-A

1 SUPPLIED IN LOOSE PIECE

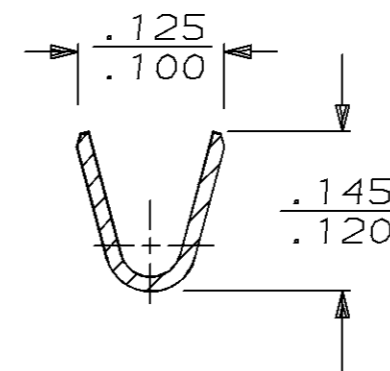
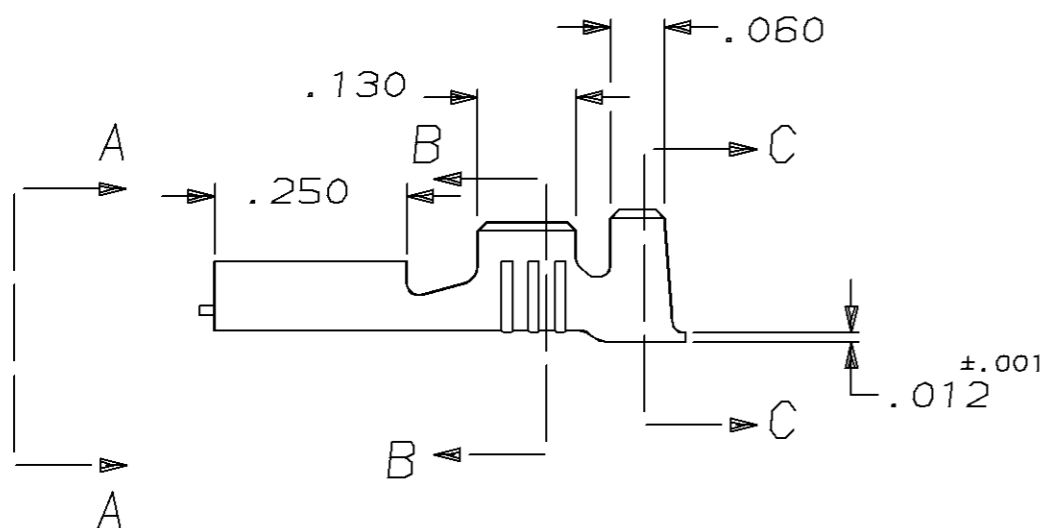

SECTION B-B

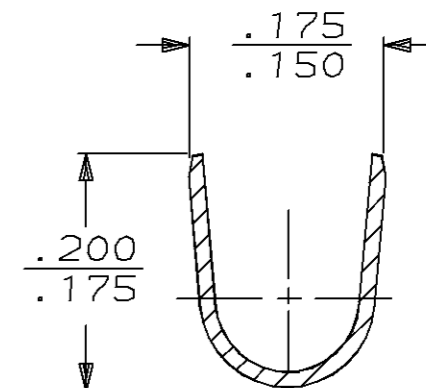

SECTION C-C

42452-2	.000080 MIN TIN	.090-.130 DIA	20-16 AWG	.020	42566-2
42452-1	-	.090-.130 DIA	20-16 AWG	.020	42566-1
STRIP FORM	FINISH	INSUL RANGE	WIRE SIZE	MATING TAB THK ±.001	PART NO
DO NOT SCALE PRINT. UNLESS SPECIFIED DIMENSIONS ARE IN INCHES. TOLERANCES ON: 2 PLC DEC ± - 3 PLC DEC ± .010 ANGLES ± -			DR 3/5/93 JR RUTH	AMP AMP Incorporated Harrisburg, PA 17105-3608	
MATERIAL H04 BRASS			CHK 3/5/93 MS FEHER		
FINISH SEE TABLE			APPD 3/5/93 C MEYERS	NAME RECEPTACLE, FASTON, .187 SERIES	
			APPD 3/5/93 R REINER	SIZE B	CAGE CODE 00779
			PRODUCT SPEC -	DRAWING NO C=42566	
			APPLICATION SPEC -	SCALE 4:1	SHEET 1 OF 1
			WEIGHT -		

THIS DRAWING IS A CONTROLLED DOCUMENT FOR AMP INCORPORATED. IT IS SUBJECT TO CHANGE AND THE CONTROLLING ENGINEERING ORGANIZATION SHOULD BE CONTACTED FOR THE LATEST REVISION.